

HANECO LED SECURITY LIGHT INSTALLATION GUIDE

PROXIMA^{G2}



Please read these installation instructions carefully before installing or maintaining this equipment. The product is designed for installation and maintenance in accordance with relevant Australian standards (AS/NZS3000), by an authorised and licensed electrician. The installation instructions were correct at the time of print. To reflect changes in technology and Australian and New Zealand standards; Haneco reserves the right to amend the instructions without notice. Updated guidelines can be found on relevant brand web site.

PRODUCT NAME: PROXIMA^{G2} Outdoor LED Security Spotlight

Issue Date: 28/08/2024

Product code	PROXIMA-12	PROXIMA-24
Power	12 W	24 W
CCT	3000 / 4000 / 5700 K	
Electrical Classification	Class I	
IP rating	IP54	
IK rating	IK10	
Nominal voltage & Frequency	220-240Vac,50/60Hz	
Power factor	> 0.5	
Surge protection rating	Overload / Short Circuit	
Inrush current	1.28 A	
Earth leakage	20 MS	
Rated operating ambient temperature	0 to 40°C	
Electrical connection	PA12 Terminal Block	
Installation type	Surface Mount	
Warranty	3 yrs	

SENSOR

Product code	PROXIMA-PIR-B
Detection Range	160°
Ambient Light	10-2000LUX (Adjustable)
Time Delay	Minimum: 10sec ± 3sec
	Maximum: 12min ± 2min
Detection Motion Speed	0.6876 - 1.5m/s
Detection Distance	2 - 12m (adjustable)
Working Temperature	-20 to 40°C
Working Humidity	<93% RH
IP Rating	IP54
Warranty	3 yrs

NOTE: Sensor is sold separately, see product codes on following page.

Line diagrams and dimensions

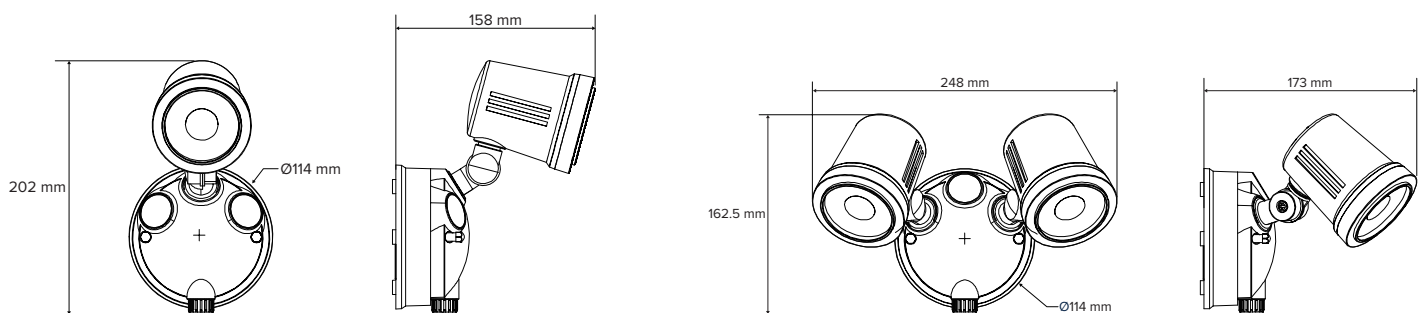

PROXIMA-12

PROXIMA-24



HANECO LED SECURITY LIGHT INSTALLATION GUIDE

PROXIMA^{G2}

Installation- Luminaire

- Turn off the power.
- Unscrew the screw caps on the front of the unit and remove the base plate.
- Feed the connection through the provided aperture.
- Secure the base plate to the wall using the screw holes.
- Connect the power source to the "N" (blue wire) and "L" (brown wire) as per the wiring diagram.
- Reattach the lamp to the base with the screws, and then turn the power back on.

Fitting Code:	PROXIMA-12
	PROXIMA-24
Sensor Code:	PROXIMA-PIR-B

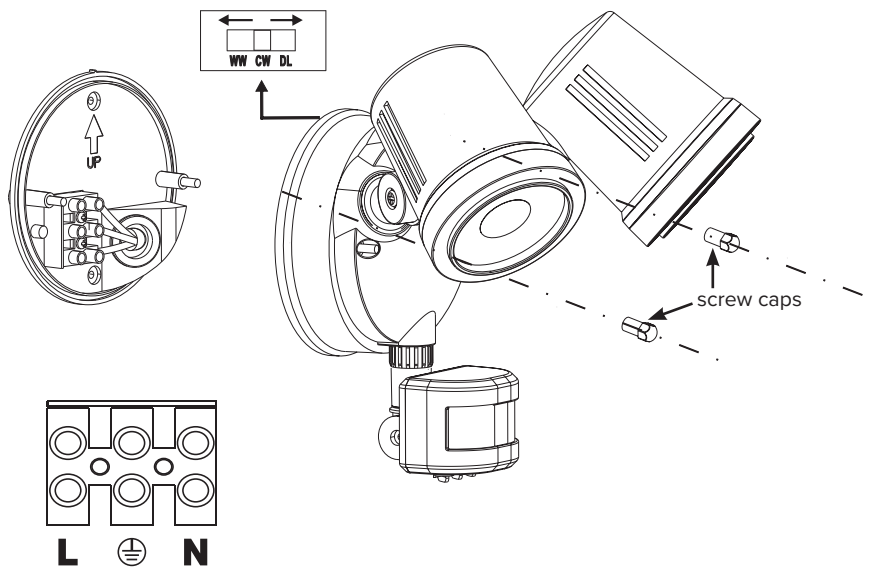

Sensor Feature

When the LUX dial is set to the sun symbol, the light will activate in any lighting condition. To have it turn on only when it's dark (below 10 lux), set the dial to the moon symbol.

Detection Range:

The SENS dial adjusts the detection range, starting at 2 meters and extending up to 12 meters by turning the dial towards the + symbol.

Daylight Threshold:

When the LUX dial is turned to the sun symbol, the light will operate in any light. To have it operate only when it is dark (less than 10 lux), turn the dial towards the moon symbol.

Sensor Hold Time:

Any new motion will reset the timer and delay the light turning off.

Manual Override Function

To deactivate the sensor, turn the wall switch OFF and ON twice within three seconds. This will override the sensor, keeping the light on continuously when switched on.

To reactivate sensor mode, turn the switch off, wait 10 seconds, and then turn it back on.

Test

To test in daylight, set the TIME dial to 10S and the LUX dial to the sun symbol. After 30 seconds, the sensor should detect movement, turn on, and then off after the 10-second interval.

To configure the sensor for nighttime testing during the day, turn the LUX dial towards the moon symbol and cover the sensor to simulate darkness.

